

Wall-Mount Equipment Cabinets

Signamax wall-mount equipment cabinets are a perfect solution for small to medium IT installations, for installations where either space is limited or security requirements exist. Cabinets may also serve as alternative spaces to the telecommunications room or entrance facility.

Designed to accommodate active and passive telecommunications equipment, these cabinets are supplied in two basic versions – single-section and dual-section, and a variety of heights – from 6 to 18 rack-mount units. Removable side doors equipped with a lock allows access to the cabinet contents from left, right or rear. Front door features a lock and toughened glass for easy inspection of cabinet contents and operational status of the installed equipment. An optional set of two fans can be installed to improved active equipment cooling where necessary.

KEY FEATURES

- Compliant with CEA 310-E, IEC 297-2, DIN 41491, DIN 4144 standards
- Single- and dual-section designs
- Heights – from 6 to 18 RMU
- Three levels of depth (450 mm (17.7 in), 550 mm (21.7 in), 600 mm (23.6 in))
- Cold-rolled steel construction: bearing elements – 1.5 mm (0.06 in), rear panel – 0.8 mm (0.03 in)
- 60 kg (132 lb) static load
- Removable side doors with locks
- 180-degree-swing toughened-glass front door with lock, also removable
- Equipment mounting hardware based on the cage-nut standard – easy replacement of damaged fasteners, protection of mounting flanges
- Knockout cable entry slots – top and bottom; additional slots in dual-section cabinets
- Pre-fabricated holes and fenders for mounting fan assemblies
- High-impact epoxy-powder anticorrosive paint

ORDERING INFORMATION

Wall-Mount Equipment Cabinets

Part Number	Description
WEC-S-xx-600/450-BK	Wall-mount equipment cabinet, single section, xx RMU, W 600 mm D 450 mm, black Cabinets are supplied with a set of mounting screws/nuts/washers and a wrench. For cabinet height add following to P/N: xx=06 (6 RMU), xx=09 (9 RMU), xx=12 (12 RMU), xx=15 (15 RMU)
WEC-D-xx-600/550-BK	Wall-mount equipment cabinet, dual section, xx RMU, W 600 D 450+100 mm, black Cabinets are supplied with a set of mounting screws/nuts/washers and a wrench. For cabinet height add following to P/N: xx=06 (6 RMU), xx=09 (9 RMU), xx=12 (12 RMU), xx=15 (15 RMU), xx=18 (18 RMU)
WEC-D-xx-600/600-BK	Wall-mount equipment cabinet, dual section, xx RMU, W 600 D 500+100 mm depth, black Cabinets are supplied with a set of mounting screws/nuts/washers and a wrench. For cabinet height add following to P/N: xx=15 (15 RMU), xx=18 (18 RMU)
WEC-CF-2	Cooling fan assembly, 2 fans, 2-m (6-ft) cord with NEMA 5-15 plug, black
WEC-MH-CN-50	Mounting hardware, screw/cage-nut/washer, 50 sets in a PE bag

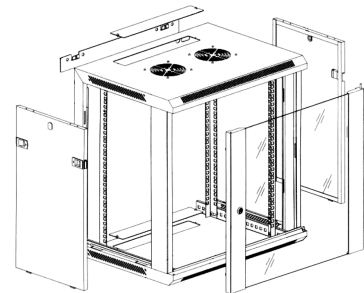
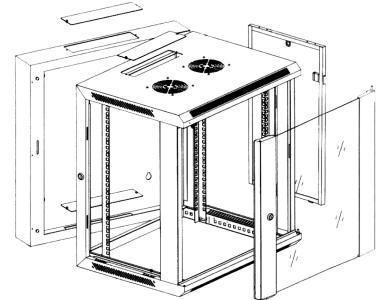

SPECIAL SPECIFICATIONS

Wall-Mount Equipment Cabinets

SPECIFICATIONS

- CONSTRUCTION**

Material: bearing frame and flanges: cold-rolled steel, 1.5 mm (0.06 in)
 rear panel: cold-rolled steel, 0.8 mm (0.03)
 housing frame: cold-rolled steel, 1.2 mm (0.05 in)
 front door: toughened glass

- MECHANICAL**

Static load: 60 kg (132 lb)

- MOUNTING DIMENSIONS**

Model	Height, RMU	Height, mm (in)	Depth, mm (in)	Weight, kg (lb)
Single-section				
WEC-S-06-600/450-BK	6	266.7 (10.50)	450.0 (17.72)	28 (62)
WEC-S-09-600/450-BK	9	400.1 (15.75)	450.0 (17.72)	29 (64)
WEC-S-12-600/450-BK	12	533.4 (21.00)	450.0 (17.72)	30 (66)
WEC-S-15-600/450-BK	15	666.8 (26.25)	450.0 (17.72)	31 (68)
Dual-section				
WEC-D-06-600/550-BK	6	266.7 (10.50)	550.0 (21.65)	30 (66)
WEC-D-09-600/550-BK	9	400.1 (15.75)	550.0 (21.65)	30 (66)
WEC-D-12-600/550-BK	12	533.4 (21.00)	550.0 (21.65)	31 (68)
WEC-D-15-600/550-BK	15	666.8 (26.25)	550.0 (21.65)	34 (75)
WEC-D-15-600/600-BK	15	666.8 (26.25)	600.0 (23.62)	36 (79)
WEC-D-18-600/550-BK	18	800.1 (31.5)	550.0 (21.65)	39 (86)
WEC-D-18-600/600-BK	18	800.1 (31.5)	600.0 (23.62)	40 (88)

- COMPLIANCE**

CEA 310-E (former EIA-310-D), IEC 297-2, DIN 41491, DIN 4144

- WARRANTY**

5-year limited component warranty

RELATED PRODUCTS

Product/Product Group	Spec Sheet #
Patch Cord and Cable Management Panels _____	PSS.PC&CM-P (B-JAN-11)

SPECIFICATIONS